

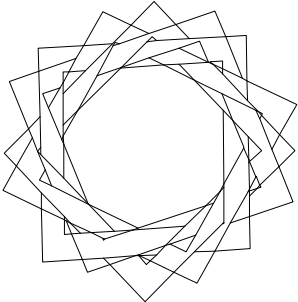



Kinderpolizei - Dienstaussweise

<p>Ausstellungsbehörde: _____</p>  <p>Ausstellungsdatum: _____</p>	 <p>Dienstaussweis Nr.: _____ Kinderpolizei des Landes</p> <p>_____</p> <p>Name: _____ Vorname: _____ Dienstgrad: _____</p>
---	--

<p>Ausstellungsbehörde: _____</p>  <p>Ausstellungsdatum: _____</p>	 <p>Dienstaussweis Nr.: _____ Kinderpolizei des Landes</p> <p>_____</p> <p>Name: _____ Vorname: _____ Dienstgrad: _____</p>
--	---

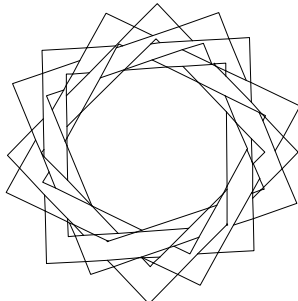
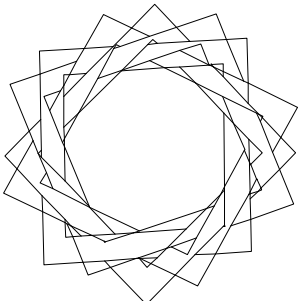
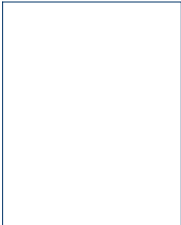
<p>Ausstellungsbehörde: _____</p>  <p>Ausstellungsdatum: _____</p>	 <p>Dienstaussweis Nr.: _____ Kinderpolizei des Landes</p> <p>_____</p> <p>Name: _____ Vorname: _____ Dienstgrad: _____</p>
---	--